

# UC-8580 Series Hardware User Manual

---

Version 2.1, November 2022

[www.moxa.com/product](http://www.moxa.com/product)

**MOXA**®

© 2022 Moxa Inc. All rights reserved.

# UC-8580 Series Hardware User Manual

The software described in this manual is furnished under a license agreement and may be used only in accordance with the terms of that agreement.

## Copyright Notice

© 2022 Moxa Inc. All rights reserved.

## Trademarks

The MOXA logo is a registered trademark of Moxa Inc.  
All other trademarks or registered marks in this manual belong to their respective manufacturers.

## Disclaimer

- Information in this document is subject to change without notice and does not represent a commitment on the part of Moxa.
- Moxa provides this document as is, without warranty of any kind, either expressed or implied, including, but not limited to, its particular purpose. Moxa reserves the right to make improvements and/or changes to this manual, or to the products and/or the programs described in this manual, at any time.
- Information provided in this manual is intended to be accurate and reliable. However, Moxa assumes no responsibility for its use, or for any infringements on the rights of third parties that may result from its use.
- This product might include unintentional technical or typographical errors. Changes are periodically made to the information herein to correct such errors, and these changes are incorporated into new editions of the publication.

## Technical Support Contact Information

[www.moxa.com/support](http://www.moxa.com/support)

# Table of Contents

<b>1. Introduction</b>	<b>4</b>
Model Descriptions and Package Checklist	4
Product Features	5
Specifications	5
Hardware Block Diagram	5
<b>2. Hardware Introduction</b>	<b>6</b>
Appearance	6
Dimensions	7
LED Indicators	8
Reset Button	8
<b>3. Hardware Connection Description</b>	<b>9</b>
Installing the UC-8580 Series	9
Wiring Requirements	9
Connecting the Power	10
Grounding the Unit	11
Connecting Data Transmission Cables	12
Connecting to an Ethernet Network	12
Connecting to a Serial Device	13
Connecting Digital Input/Output Devices	13
Connecting a USB Device	14
Connecting Wi-Fi/Cellular Modules and Installing Antennas	15
Installing SIM Cards for the Cellular Modules	20
Installing the mSATA Module	21

# 1. Introduction

---

Thank you for using Moxa's UC-8580 Series computer. The UC-8580 Series computer is a programmable communication-centric gateway offering a rich variety of communication interfaces such as Ethernet, serial, and digital inputs/outputs. This EN 50155-compliant computer is built for rail applications and comes with multiple wireless WAN gateway interfaces making it an ideal choice for building wireless communication infrastructure with 802.11 a/b/g/n/ac, and for LTE data collection and transmission.

This computer runs on the Debian Linux operating system, providing a powerful communication platform without generating too much heat, even when loaded with heavy application tasks. In addition, the mSATA socket helps you easily expand the storage capacity for large-scale data acquisition.

The UC-8580 comes in two front-panel models to support two types of antenna connectors (SMA and QMA) for wireless modules.

This chapter describes the product package checklist, product features, and hardware specifications.

## Model Descriptions and Package Checklist

The UC-8580 Series comprises the following models:

- **UC-8580-LX:** Programmable multiple-wireless computing platform for rail onboard applications, supporting up to 4 wireless modules with SMA connectors, and a -25 to 55°C operating temperature range
- **UC-8580-T-LX:** Programmable multiple-wireless computing platform for rail onboard applications, supporting up to 4 wireless modules with SMA connectors, and a -40 to 70°C operating temperature range
- **UC-8580-T-CT-LX:** Programmable multiple-wireless computing platform for rail onboard applications, supporting up to 4 wireless modules with SMA connectors, and a -40 to 70°C operating temperature range, and conformal coating
- **UC-8580-Q-LX:** Programmable multiple-wireless computing platform for rail onboard applications, supporting up to 4 wireless modules with QMA connectors, -25 to 55°C operating temperature range
- **UC-8580-T-Q-LX:** Programmable multiple-wireless computing platform for rail onboard applications, supporting up to 4 wireless modules with QMA connectors, -40 to 70°C operating temperature range
- **UC-8580-T-CT-Q-LX:** Programmable multiple-wireless computing platform for rail onboard applications, supporting up to 4 wireless modules with QMA connectors, with -40 to 70°C operating temperature range and conformal coating

The UC-8580 Series computer is shipped with the following items:

- UC-8580 Series computer
- CBL-4PINDB9F-100: 4-pin pin header to DB9 female console port cable, 100 cm
- Quick Installation Guide (printed)
- Warranty card

# Product Features

The UC-8580 Series computer includes the following features:

- Armv7 Cortex-A7 dual-core 1 GHz processor
- 1 GB DDR3L SDRAM
- 8 GB eMMC for OS
- 1 mSATA slot for expansion storage
- 2 auto-sensing 10/100/1000 Mbps Ethernet M12 ports
- 1 USB 3.0/2.0 host with Type A connector
- Up to 4 PCIe mini slots (1 PCIe/USB 2.0 and 3 USB 2.0 signals)
- Isolated power input with a wide range of 24 to 110 VDC

# Specifications



## NOTE

The latest specifications for Moxa's products can be found at <https://www.moxa.com>.

# Hardware Block Diagram

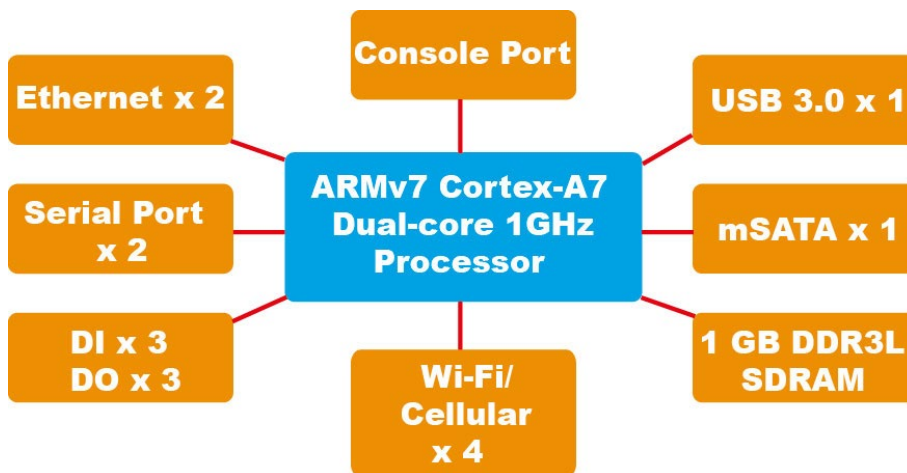

# 2. Hardware Introduction

The UC-8580 computer is compact and designed to be rugged enough for industrial applications. This chapter provides information on the appearance and dimensions of the UC-8580 and describes the LED indicators, reset button, and RTC that can help you monitor system performance and identify issues. The multiple serial ports on the UC-8580 allow you to connect different devices for wireless operation, and the reliable and stable hardware platform lets you devote your attention to developing your applications.

## Appearance

### Front View

#### SMA Model

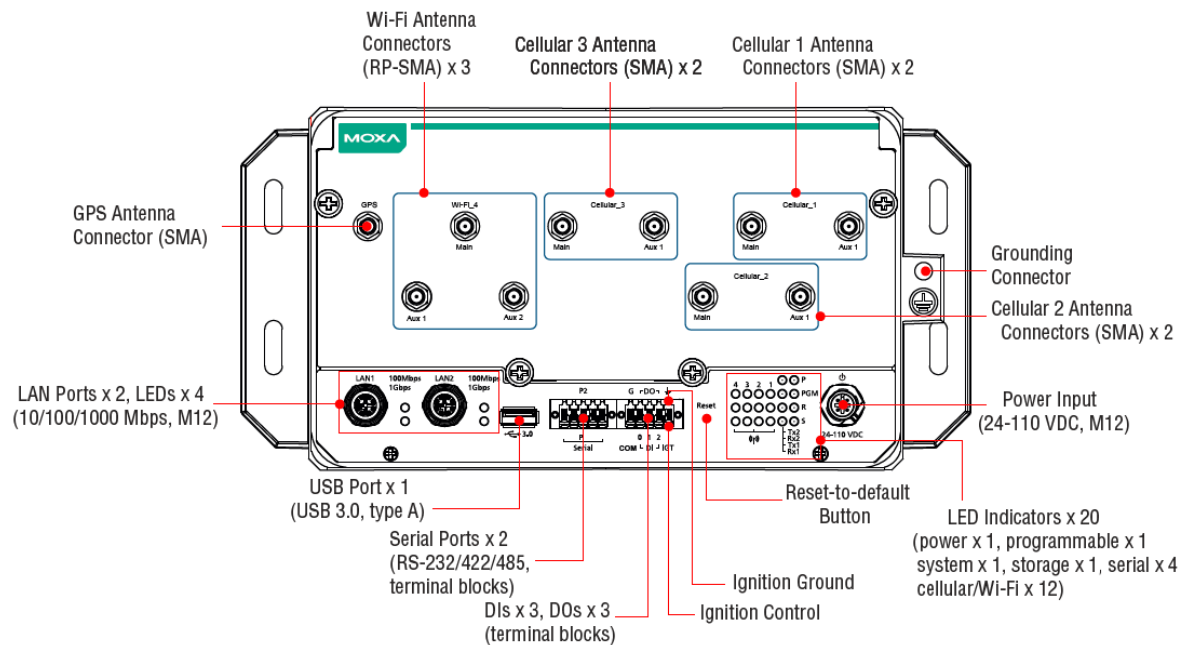

## QMA Model

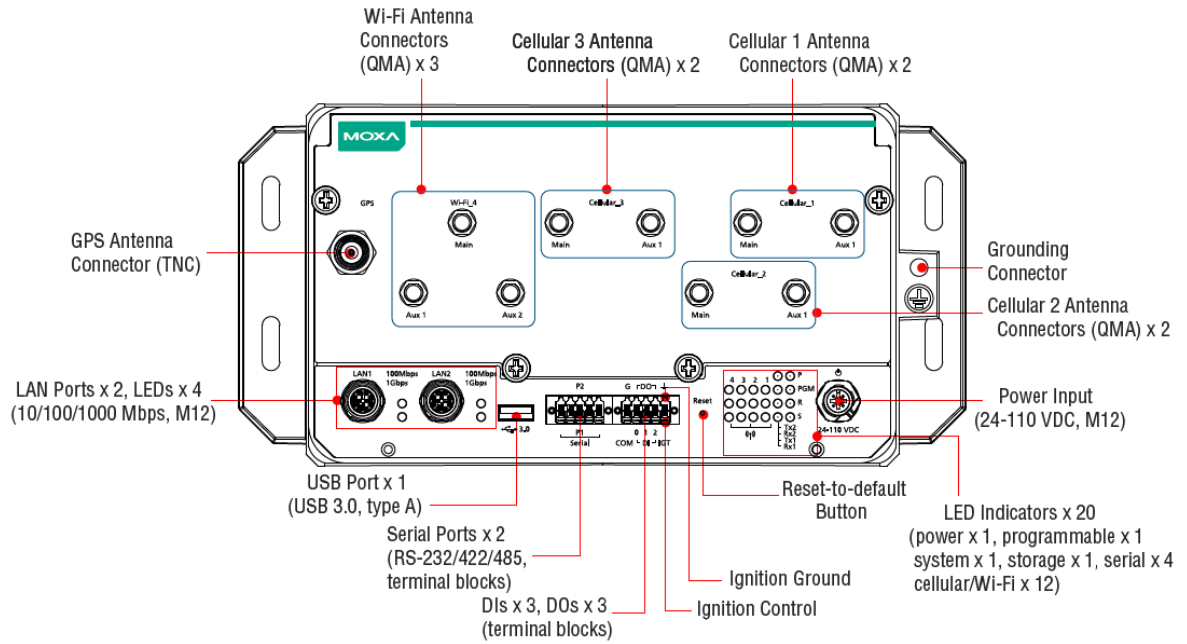

## Dimensions

Units: mm (in)

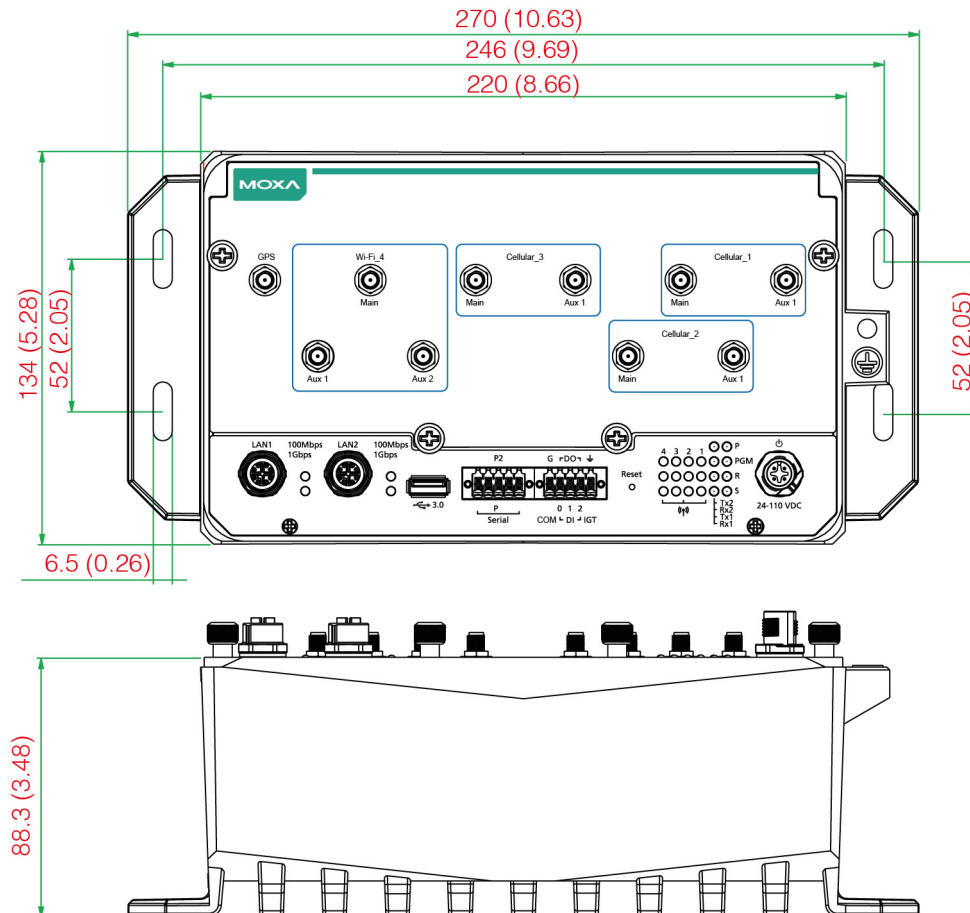

# LED Indicators

LED Name	Status	Function
P	Green	Power is on
	Off	No power input or any other power-input error
R	Green	System is ready
	Off	System is booting, OS boot-up failure, or any other system initialization error
Ethernet (located next to the Ethernet ports)	Green	Steady On: 100 Mbps Ethernet link Blinking: Data transmission is in progress
	Yellow	Steady On: 1000 Mbps Ethernet link Blinking: Data transmission is in progress
	Off	Data transmission speed at 10 Mbps or the cable is not connected
Serial Tx2 Rx2 Tx1 Rx1	Green	Tx: Data transmission is in progress
	Yellow	Rx: Receiving Data
	Off	No operation on the serial ports
S	Green	Data is being accessed from either the eMMC or the mSATA module
	Off	No data is being accessed
PGM	Red	Programmable LED for user-defined function
Wireless 	Green	The number of glowing LEDs indicate the wireless signal strength as follows:
		3 Green: Excellent
		2 Green: Good 1 Green: Poor
	Off	No wireless signal

## Reset Button

Press the Reset button on the front panel of the UC-8580 computer to set the system to the factory default values and reboot the system automatically. The **R** LED will flash for 5 seconds and then maintain a steady glow when the system has rebooted. All system configurations will be reset to the factory default once the computer restarts. The illustration below shows an SMA model.

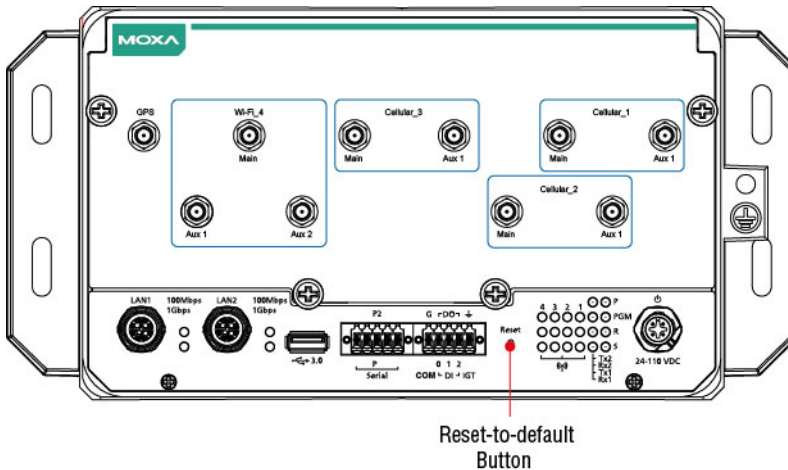



# 3. Hardware Connection Description

In this chapter, we show how to connect the UC-8580 computer to the network and to various devices.

## Installing the UC-8580 Series

### Wall or Cabinet Mounting

Use two screws per side to mount the UC-8580 computer on to a wall or in a cabinet. The illustration below shows an SMA model.

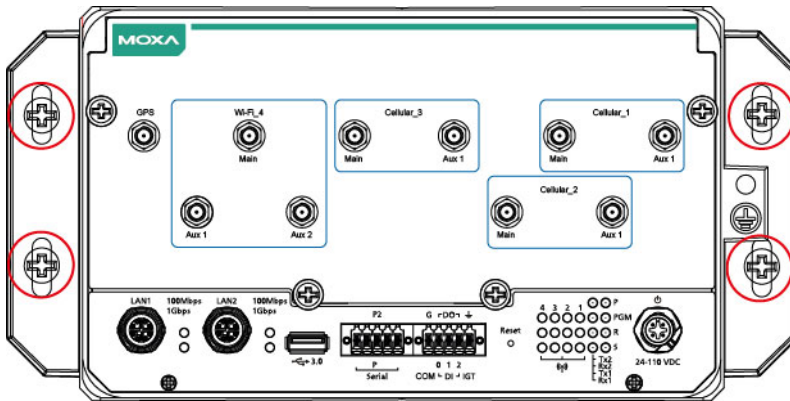

## Wiring Requirements

Be sure to read and follow these common safety precautions before proceeding with the installation of any electronic device:

- Use separate paths to route wiring for power and devices. If power wiring and device wiring paths must cross, make sure the wires are perpendicular at the intersection point.



### NOTE

Do not run the wires for signal or communication and power wiring in the same wire conduit. To avoid interference, wires with different signal characteristics should be routed separately.

- Use the type of signal transmitted through a wire to determine which wires should be kept separate. The rule of thumb is that wiring that shares similar electrical characteristics can be bundled together.
- Keep input wiring and output wiring separate.
- It is advisable to label the wiring to all devices in the system for easy identification.



## ATTENTION

### Safety First!

Be sure to disconnect the power cord before installing and/or wiring your UC-8580 computer.

### Wiring Caution!

Calculate the maximum possible current in each power wire and common wire. Observe all electrical codes dictating the maximum current allowable for each wire size. If the current goes above the maximum ratings, the wiring could overheat, causing serious damage to your equipment.

### Temperature Caution!

Be careful when handling the unit. When the unit is plugged in, the internal components generate heat, and consequently the outer casing may feel hot to the touch.

## Connecting the Power

Connect the 24 to 110 VDC power line with M12 A-coded connector to the UC-8580 Series computer. If the power is supplied properly, the P LED will glow a solid green after a 25 to 30-second delay. The power input location and pin definition are shown in the following figures:

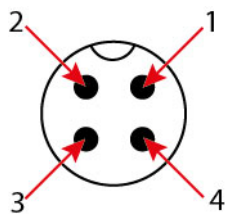

PIN	Definition
1	V+
2	N.C.
3	V-
4	N.C.

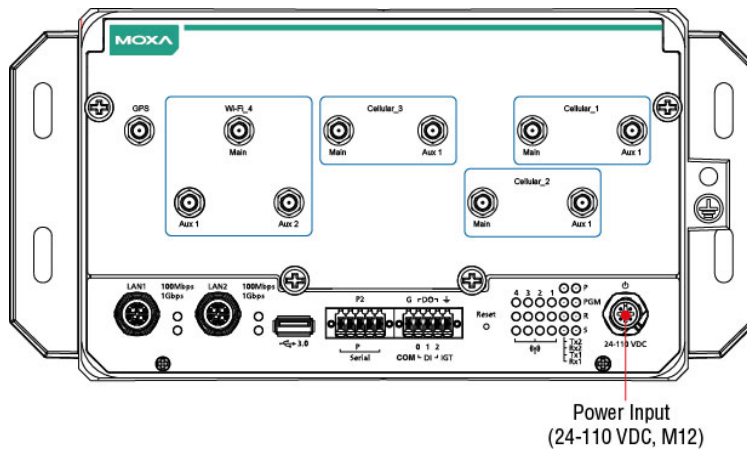

# Grounding the Unit

Grounding and wire routing help limit the effects of noise due to electromagnetic interference (EMI). Run the ground connection from the ground screw to the grounding surface prior to connecting the power.



## ATTENTION

This product is intended to be mounted on a well-grounded mounting surface, such as a metal panel.

The grounding connector is located on the front panel. Connect the grounding wire to an appropriate grounded metal surface.

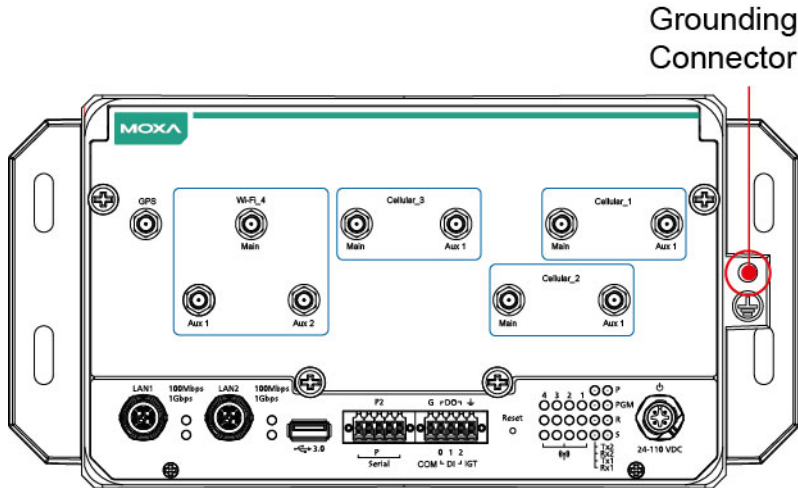

# Connecting Data Transmission Cables

In this section, we describe how to connect the UC-8580 embedded computer to a network and serial devices.

## Connecting to an Ethernet Network

Connect your network cable to the embedded computer's Ethernet port. The other end of the cable should be connected to your Ethernet network. When the cable is properly connected, the green LED corresponding to the Ethernet port turns on indicating a valid connection.

Two 10/100/1000 Mbps Ethernet ports with M12 X-coded connectors are located on the rear panel of the UC-8580 computer. See the following figure for the location of the Ethernet ports and the pin assignments. The figure is based on the SMA model.



### NOTE

If you are using your own Ethernet cable, make sure that the pin assignment on the connector of the Ethernet cable matches the pin assignment shown below.

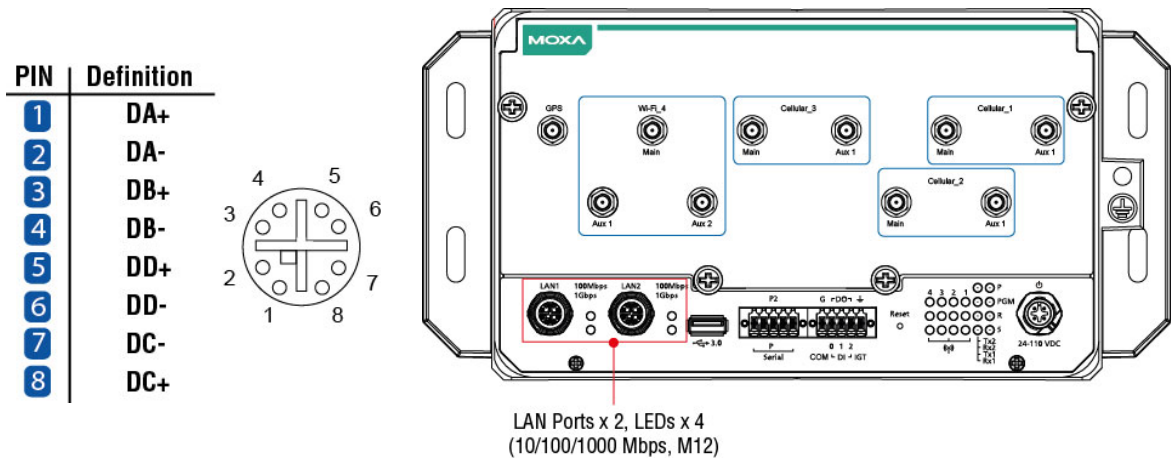

## Connecting to a Serial Device

Use serial cables to connect your serial devices to the computer's serial ports. Serial ports P1 and P2 have terminal blocks and can be configured for RS-232, RS-422, or RS-485 communication. The pin location and assignment of the serial ports are shown in the following diagrams. The diagrams are based on the SMA model.

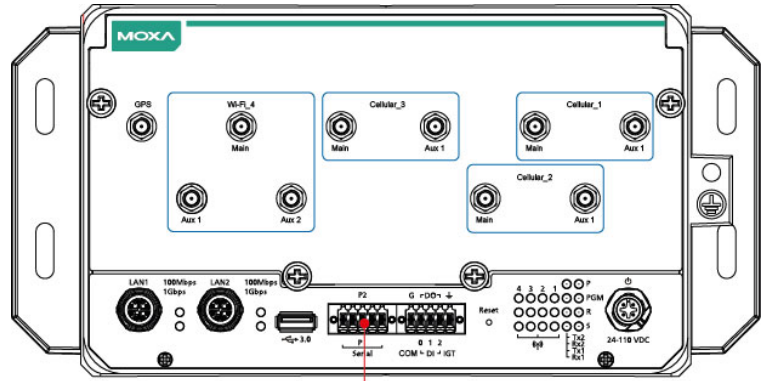
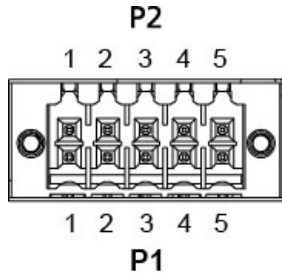

Serial Ports x 2  
(RS-232/422/485,  
terminal blocks)

Pin	1	2	3	4	5
RS-232	TxD	RxD	RTS	CTS	GND
RS-422	TxD+	TxD-	RxD+	RxD-	GND
RS-485	-	-	DATA+	DATA-	GND

## Connecting Digital Input/Output Devices

The UC-8580 computer comes with a 3-channel digital input and 3-channel digital output terminal block that you can use to connect your digital devices. The DI/O pin assignments and wiring methods are shown below:

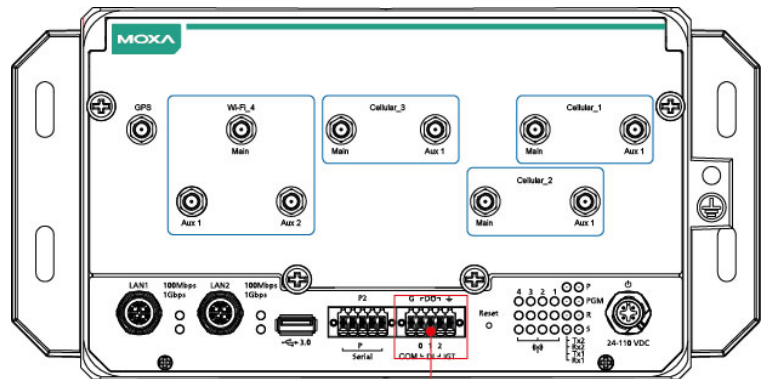
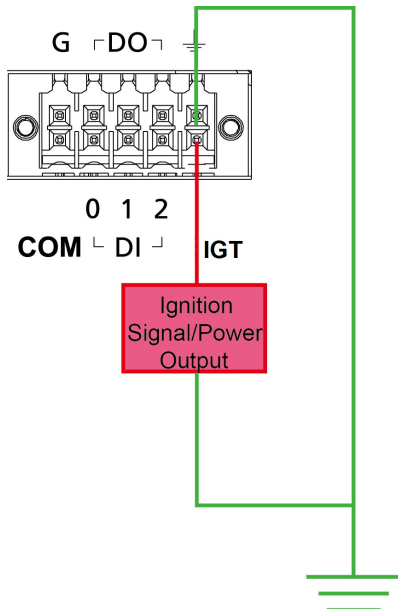

DI x 3  
DO x 3

### DI Dry Contact

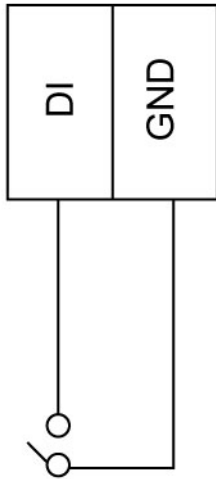

### DI Wet Contact

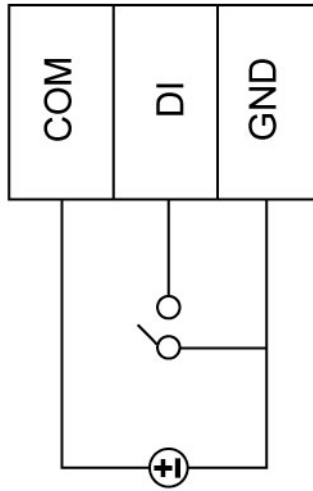

### DO Contact Sink

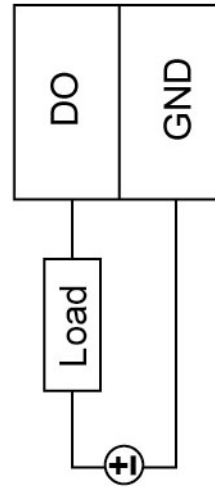

## Connecting a USB Device

The UC-8580 computer is provided with a USB 3.0 port on the front panel for connecting a USB device.

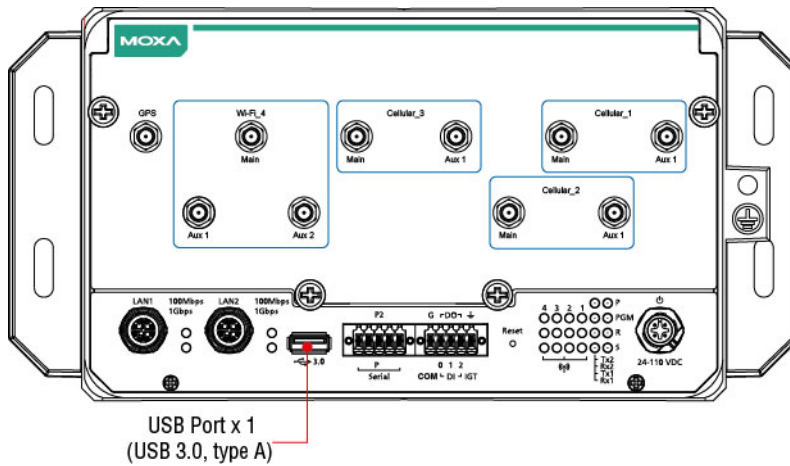

# Connecting Wi-Fi/Cellular Modules and Installing Antennas

The UC-8580 computer is provided with four sets of antenna holes for installing antennas for the Wi-Fi and cellular modules. Unfasten the four screws on the front panel and lift up the panel to check the location of the Wi-Fi/cellular module sockets. The illustration below shows an SMA model.

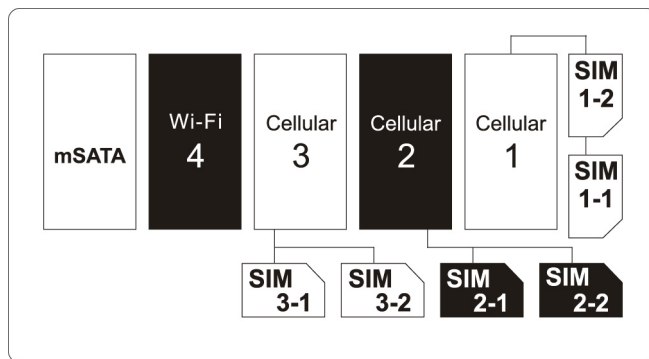
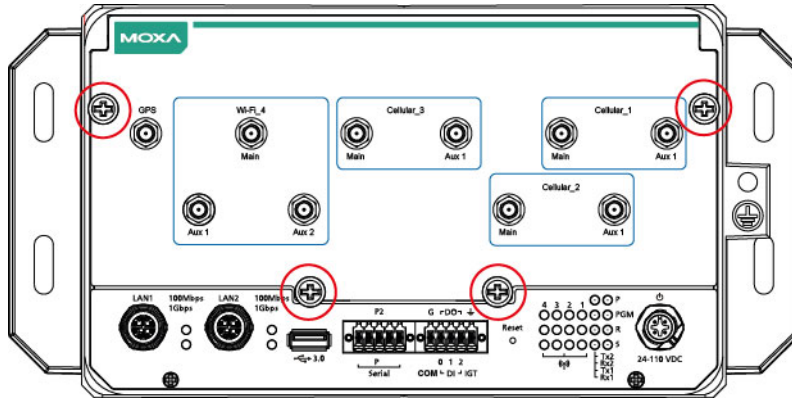

Socket Name	Usage
Cellular_1	Cellular module
Cellular_2	Cellular module
Cellular_3	Cellular module
Wi-Fi_4	Wi-Fi module

You will need to install the SIM cards for the cellular modules in the designated SIM-card slots. For the cellular module in socket 1, insert SIM cards in the SIM 1-1 and SIM 1-2 slots. The SIM cards for the cellular module in socket 3 should be inserted in the SIM 3-1 and SIM 3-2 slots.

The Wi-Fi/cellular module package includes 1 wireless (Wi-Fi or cellular) module, 2 or 3 antenna cables and connectors, 1 black tape, 1 tag sheet, 2 screws, 2 locking washers, and 2 nuts.

### Accessories for the SMA Model

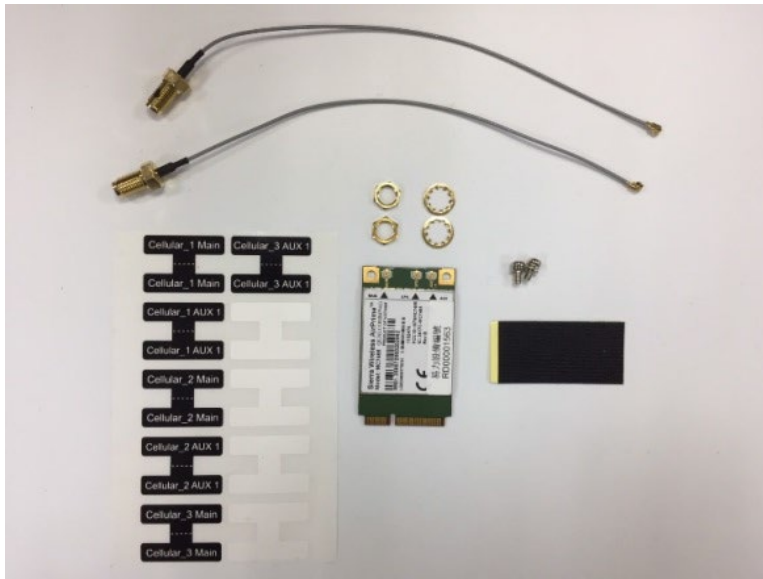

### Accessories for the QMA Model

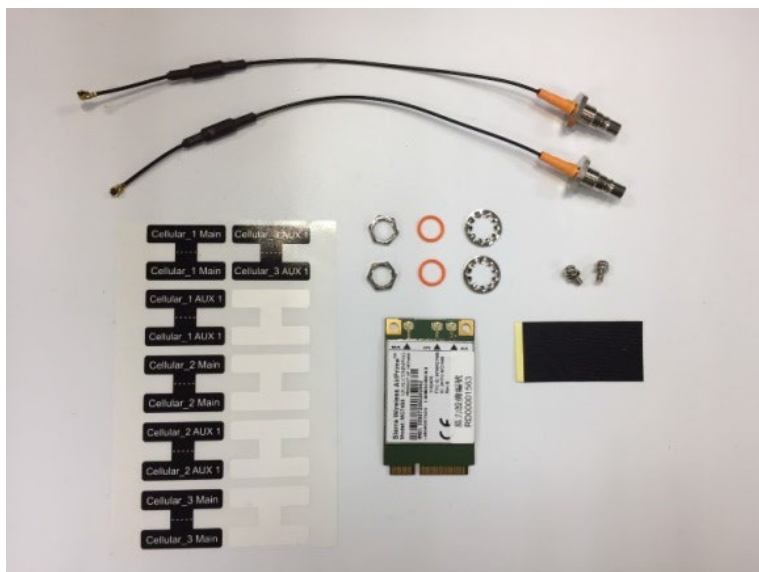



Follow these steps to install a wireless (Wi-Fi/cellular) module.

1. Remove the plastic protective film on the thermal pads that come attached to the wireless module.

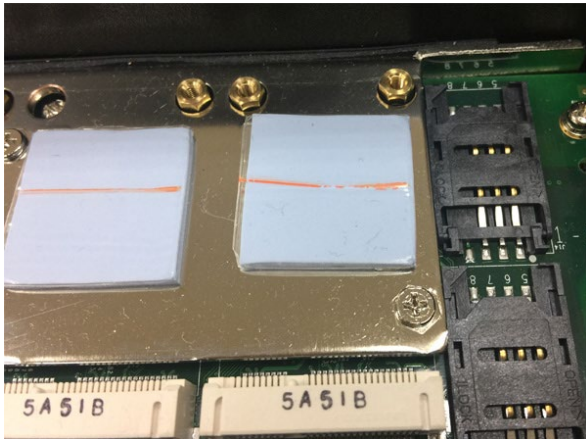

2. Insert the wireless module in the designated socket and tighten the two screws on the module.



- Attach the flat end of the antenna cable to the connector marked **MAIN** on the module and insert the other end of the cable with the connector tube into the antenna hole marked **MAIN** on the front panel of the computer.

You must first remove the black cover on the antenna hole and insert the connector tube through the back side of the front panel before you can attach the antenna cable.

Follow the procedure described above to attach the AUX antenna cable.



- Use the black tape provided in the package to secure the antenna cables to the module. Attach tags (also provided in the package) to the cables to help identify them easily as shown in the picture below:

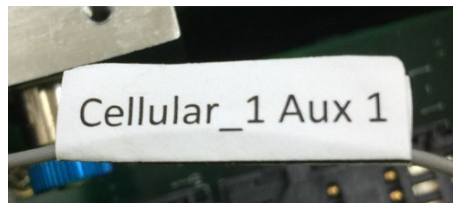

- Insert the antenna connectors through the D-shaped antenna holes on the front panel. Be sure to align the D shaped connector tube with the antenna hole before you do so.

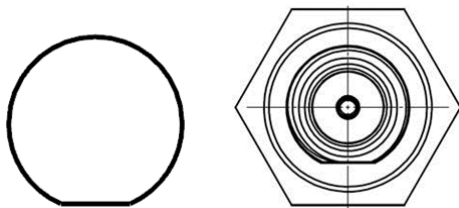

Secure the antenna connectors to the front panel by inserting the locking washers through the connector tube followed by the nut and then tightening the nut onto the threaded protection ring.

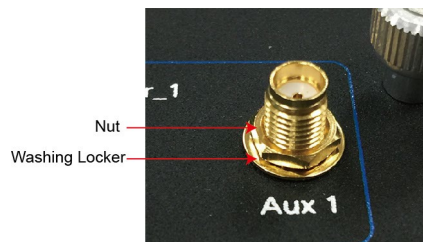

Refer to the following figures for the location of each antenna connector, including the connector for a GPS antenna.

## SMA Model

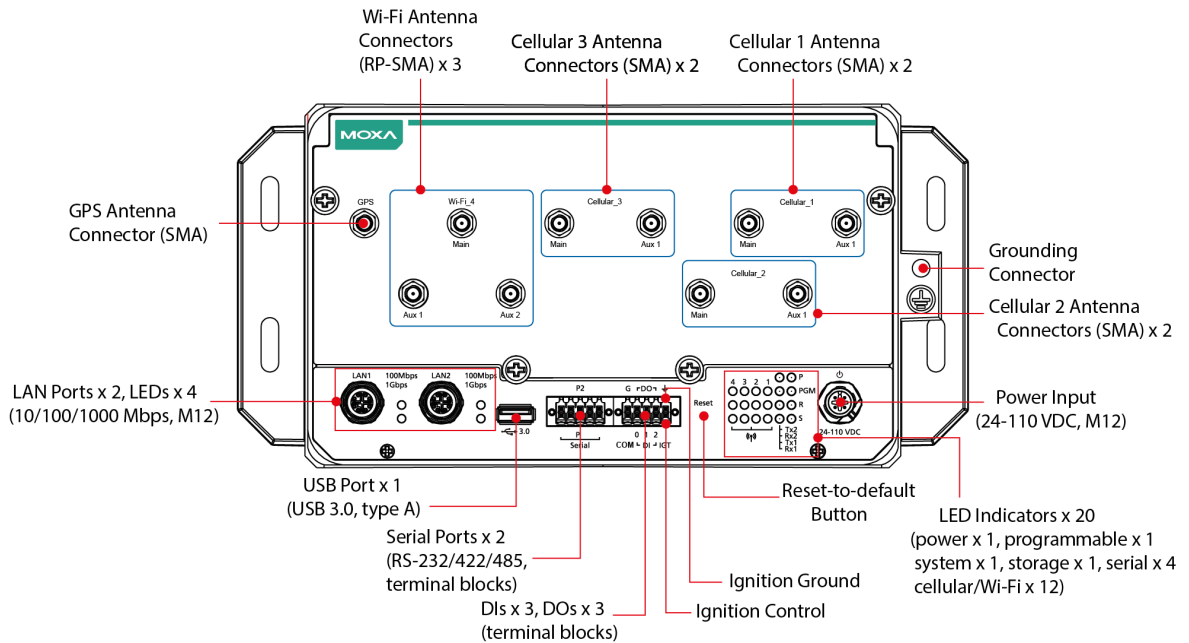

## QMA Model

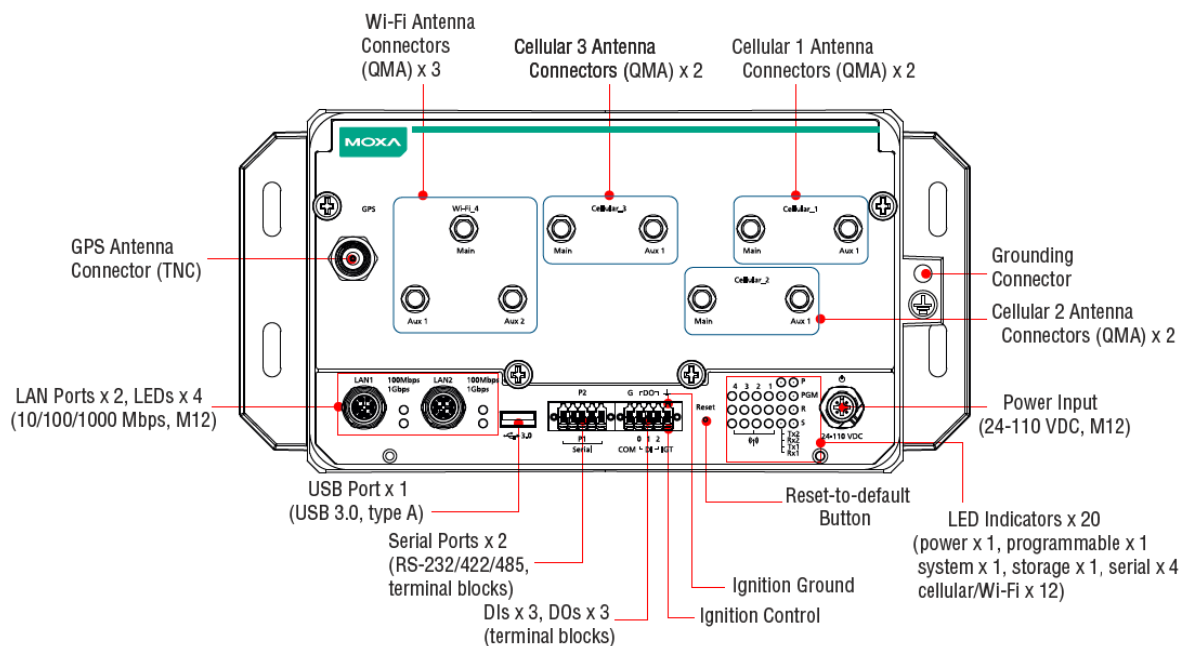

Use the procedure described above to install other Wi-Fi or cellular modules.



## NOTE

The Wi-Fi module installed in socket 4 requires three antennas. Make sure all three antennas are installed and secured properly before you use the module.

# Installing SIM Cards for the Cellular Modules

Each cellular module supports 2 SIM cards. To install SIM cards for the cellular modules, do the following:

1. Find the location of the SIM card socket.

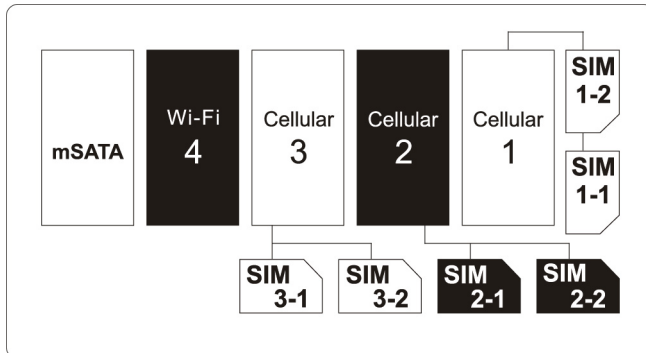

2. Pull up the SIM card holder and insert the SIM card.

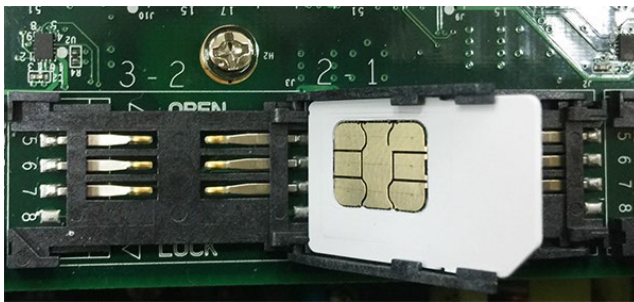

3. Push down the SIM card holder until the SIM card is secured in place.

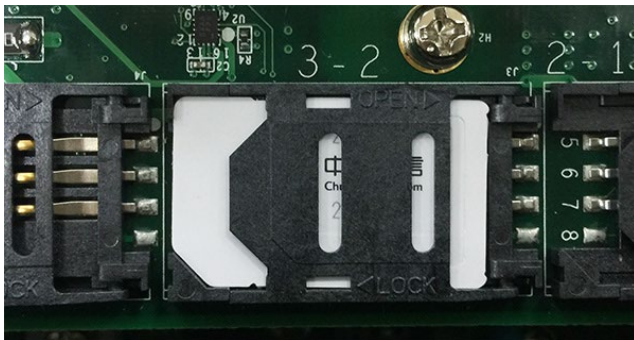

# Installing the mSATA Module

The UC-8580 computer is provided with one storage socket for installing a mSATA module. To install the mSATA module, do the following:

1. Locate the mSATA socket.

It is the left most socket that you see when you open the front panel of the computer.

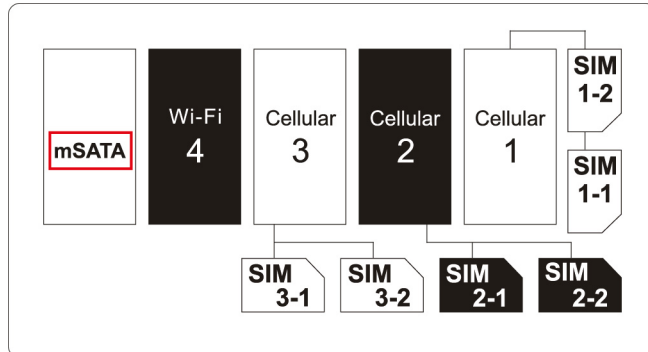

2. Insert the mSATA module in the socket.
3. Fasten the two screws on the module to secure the module.

